

# BUILDER SERIES

**Oasis**

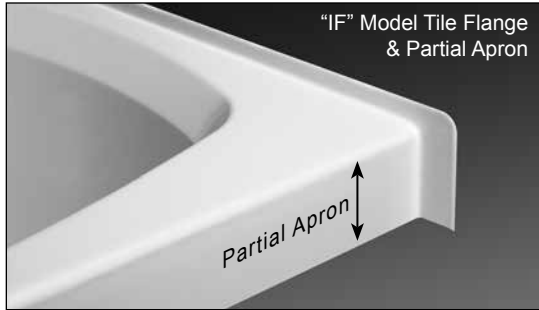

**Home Innovation**  
LAB CERTIFIED™



60-INCH WIDE MODELS

**OV-S-6042** (Tile Flange, Full Apron)

**OV-IF-6042** (Tile Flange, Partial Apron)

Rough-In Dimensions	OV-S-6042 OV-IF-6042	60" wide x 43-1/4" deep x 21-1/4" high
---------------------	-------------------------	--

Finished Dimensions	OV-S-6042 OV-IF-6042	60" wide x 42" deep x 20" high
---------------------	-------------------------	--------------------------------

### Unit Features

- Gelcoat Surface
- 2" Dia. RH or LH Drain (see reverse side for location)
- 2-1/2" Dia. Overflow (see reverse side for location)
- "S" Model: Integral Tile Flange & Full Apron
- "IF" Model: Integral Tile Flange & Partial Apron
- Pre-Leveled Block Base System
- Balsa Wood Core Floor Structure
- Textured Floor Pattern

### Special Notes

- Whirlpool System Available (see reverse side for details)
- UL Listed Whirlpool Systems
- Removable Access Panel Included on "S" Model w. System
- Model Available In Self-Rimming Design

### Unit / System Order Number

Gelcoat: OV-S-6042 R or L Drain / OND (soaking tub)  
OV-S-6042 R or L Drain / 6P (Builder System)  
OV-S-6042 R or L Drain / CWS (Carress System)

OV-IF-6042 R or L Drain / OND (soaking tub)  
OV-IF-6042 R or L Drain / 6P (Builder System)  
OV-IF-6042 R or L Drain / CWS (Carress System)

### System Trim

Standard 6P & CWS Trim (order code): White trim on White unit (WHT) - Bone trim on Bone unit (BON) - Biscuit trim on Biscuit unit (BSC)

### Order Number / Description

CWS: *Carress System* includes: 4-Adjustable side jets, 2-rotating foot jets, 2-micro pulse back jets, variable flow control, twin air controls, electronic system control, 13.0 amp pump/motor, and a removable access panel (S model).

Options: In-Line Heater (1\*) (order: ILH)  
 Trim Upgrade (1\*)  
 Chrome (order: CWS-CHR)  
 Brushed (Satin) Nickel (order: CWS-SNK)

### Order Number / Description

6P: *Builder System* includes: 6-Adjustable jets, twin air controls, pneumatic system control, 5.50 amp pump/motor, and a removable access panel (S model).

Options: In-Line Heater (1\*) (order: ILH)

Notes: (1\*) Factory installed options  
 (2\*) Includes system control upgrade

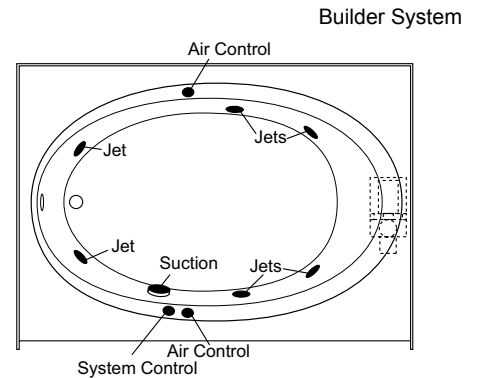
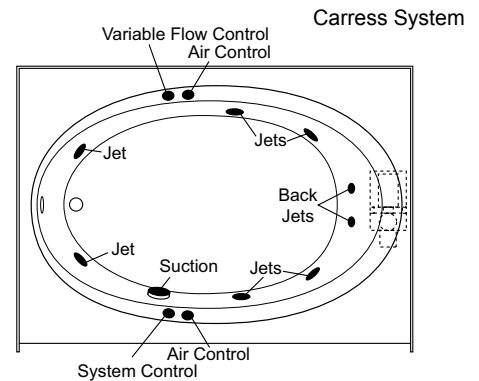
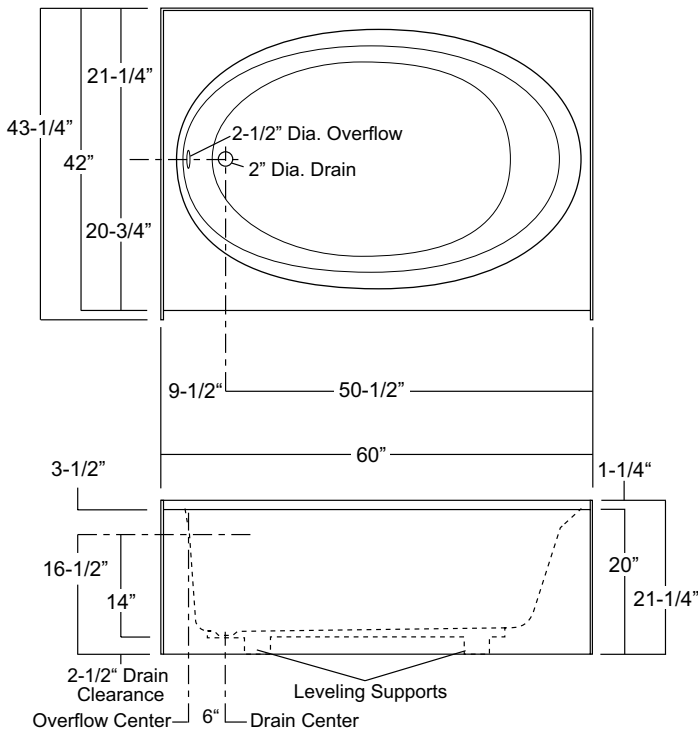

### OV-S-6042L (illustrated)

Sump Dimen: 43-1/2" long x 29-1/2" wide x 16-3/4" deep

Sump Capacity: 62 gal. (unoccupied - to overflow)

Whirlpool Operating: 32 gal.