

ISLAND SERIES BATH



Home Innovation
LAB CERTIFIED™



59-INCH MODEL

Oasis



FSA-OV1P-5928CD

Finished Dimensions

59" long x 27-7/8" wide x 26-1/2" high

Unit Features

- Vacuum Formed White Acrylic
- Single-Piece Design
- 2" Dia. Center Drain (see reverse side for location)
- 3-1/2" Slotted Overflow (see reverse side for location)
- Raised Neck Area
- Extra Deep Bathing Sump
- Concealed Adjustable Leveling Legs

Special Notes

- Includes White Center Toe-Tap Drain Assembly & Built-In Integral Overflow

Acrylic Unit / System Order Number

FSA-OV1P-5928CD WHT (center drain - soaking tub)

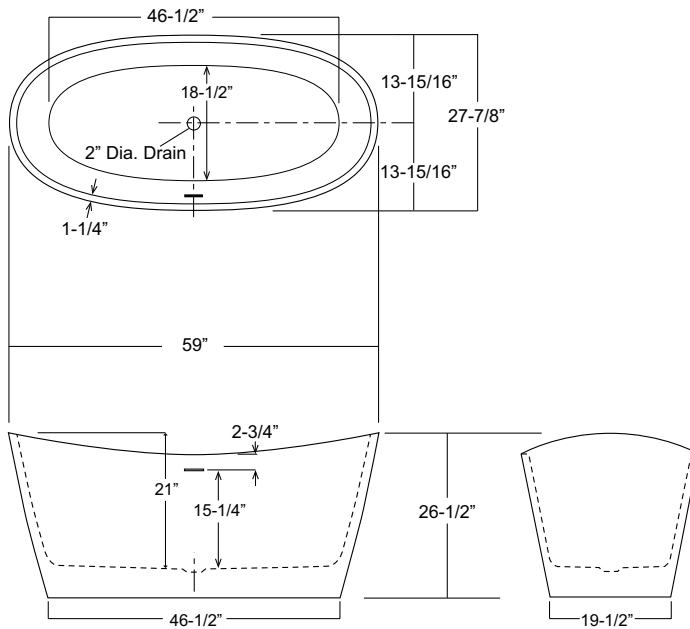

Sump Bottom Dimen: 46-1/2" long x 18-1/2" wide x 18" deep
Sump Capacity: 55 gal. (unoccupied - to overflow)
Whirlpool Operating: NA