

36-INCH TO 48-INCH SHOWER BASES

Oasis



MODELS

SP-1
SP-4
SP-3
SP-2
SP-8

Rough-In Dimensions	Model	Dimensions
	SP-1	36" wide x 37-1/4" deep x 7-1/4" high
	SP-4	36" wide x 47-5/8" deep x 7-1/4" high
	SP-3	41-7/8" wide x 42-3/4" deep x 7-1/4" high
	SP-2	48" wide x 35" deep x 7-1/4" high
	SP-8	48" wide x 36-3/4" deep x 7-1/4" high

Finished Dimensions	Model	Dimensions
	SP-1	36" wide x 36" deep x 6" high
	SP-4	36" wide x 47-5/8" deep x 6" high
	SP-3	41-7/8" wide x 41-1/2" deep x 6" high
	SP-2	48" wide x 33-3/4" deep x 6" high
	SP-8	48" wide x 35-1/2" deep x 6" high

Unit Features

- One-Piece Gelcoat Surface
- 3-3/8" Center Drain (see reverse side for location)
- Integral Tile Flange
- Balsa Wood Core Floor Structure
- Textured Floor Pattern

Special Notes

- Individually Packaged In Cartons

Unit / System Order Number

Gelcoat: SP-1
SP-4
SP-3

Unit / System Order Number

Gelcoat: SP-2
SP-8

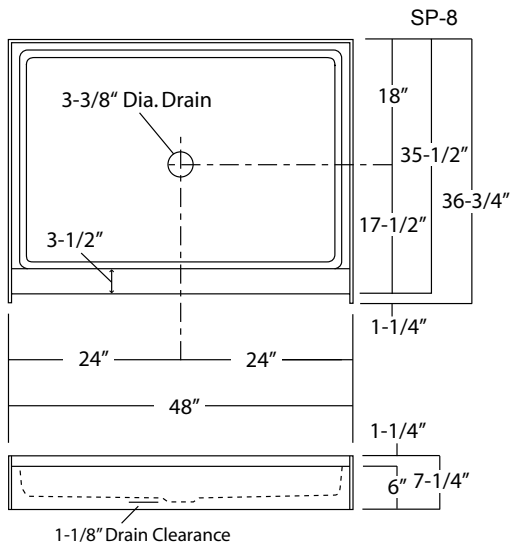
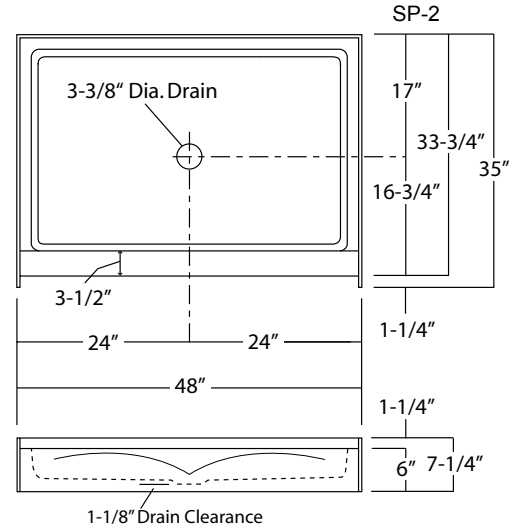
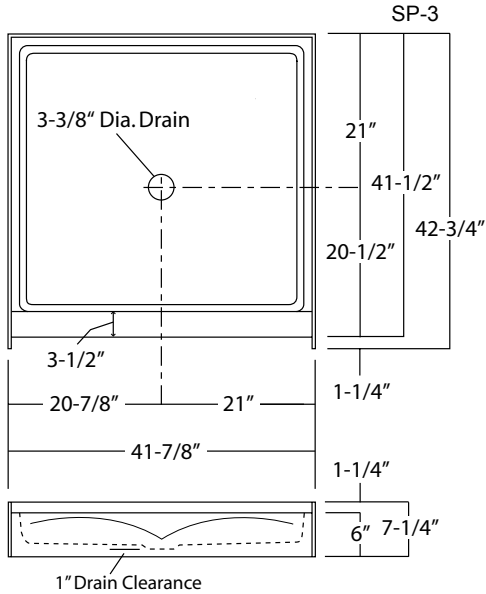
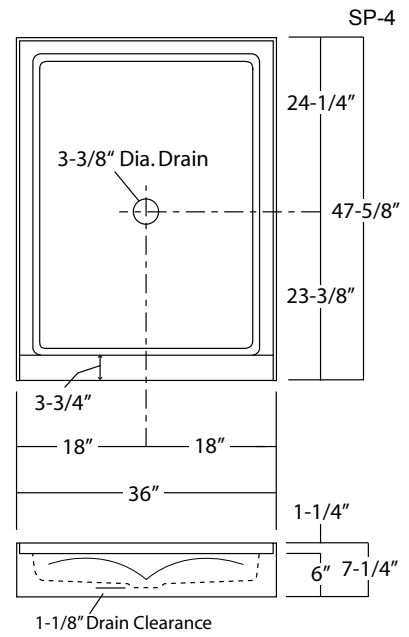
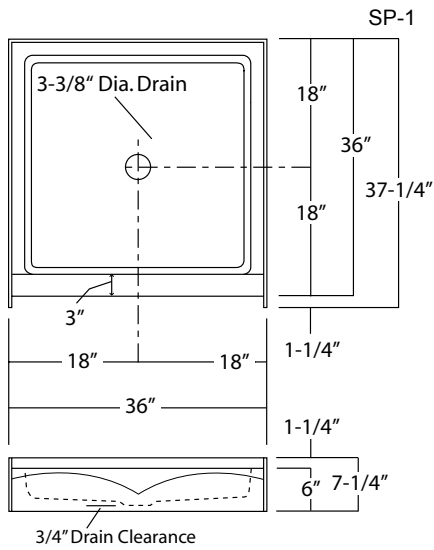

NOTE: Critical enclosure dimensions should be taken directly from the installed shower base with finished wall surround.

Photographic images may include optional components and appear different than actual product.
 Dimensions shown are maximum. Due to the nature of the materials involved, actual unit dimensions can vary (tolerances: +0 / -3/8 inch).
 Oasis reserves the right to modify or discontinue product and/or associated equipment without prior written or verbal notification or obligation.