

BUILDER SERIES



66-INCH WIDE MODEL

Prestige 3466 (Self-Rimming)

Unit Dimensions

66" wide x 34-1/4" deep x 21" high

Unit Features

- Vacuum Formed Acrylic
- 2" Dia. End Drain (see reverse side for location)
- 2-1/2" Dia. Overflow (see reverse side for location)
- Twin, Contoured Armrests
- Pre-Leveled Block Base System
- Balsa Wood Core Floor Structure
- Textured Floor Pattern

Special Notes

- Whirlpool System Available (see reverse side for details)
- Air System Available (see reverse side for details)
- UL Listed Whirlpool & Air Systems
- Models Available w. Integral Tile Flange

Unit / System Order Number

Acrylic: TR-B-220 / 0ND (soaking tub)
TR-B-220 / 6P (Builder System)
TR-B-220 / CWS (Carress System)
TR-B-220 / AR2 (Revive Air System)

System Trim

Standard 6P & CWS Trim (order code): White trim on White unit (WHT) - Bone trim on Bone unit (BON) - Biscuit trim on Biscuit unit (BSC)

Order Number / Description

CWS: *Carress System* includes: 4-Adjustable side jets, 2-rotating foot jets, 2-micro pulse back jets, variable flow control, twin air controls, electronic system control, and 11.0 amp pump/motor.

Options: In-Line Heater (1*) (order: ILH)
 Ozone Generator (1*) (order: OZG)
 Chromatherapy Pkg (1*, 2*) (order: CLT)
 Water Level Sensor (1*, 2*) (order: LWV)
 Trim Upgrade (1*)
 Chrome (order: CWS-CHR)
 Brushed (Satin) Nickel (order: CWS-SNK)
 Polished Brass (order: CWS-PBR)

Order Number / Description

6P: *Builder System* includes: 6-Adjustable jets, twin air controls, pneumatic system control, and 5.80 amp pump/motor.

Options: In-Line Heater (1*) (order: ILH)
 Ozone Generator (1*) (order: OZG)

AR2: *Revive Air System* (3*) includes: (49) Perimeter air ports, electronic system control, and 600-watt blower with ceramic heater.

Notes: (1*) Factory installed options
 (2*) Includes system control upgrade
 (3*) Available on acrylic models only

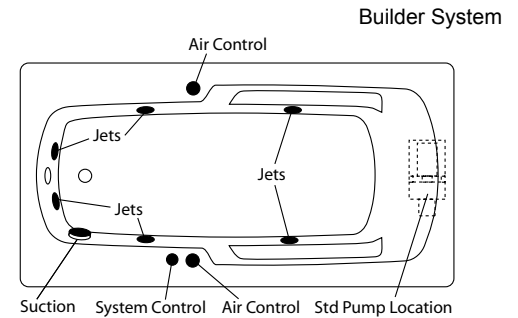
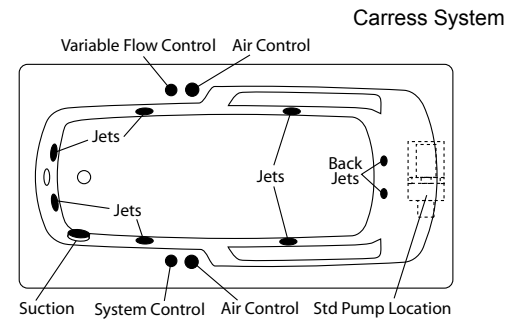
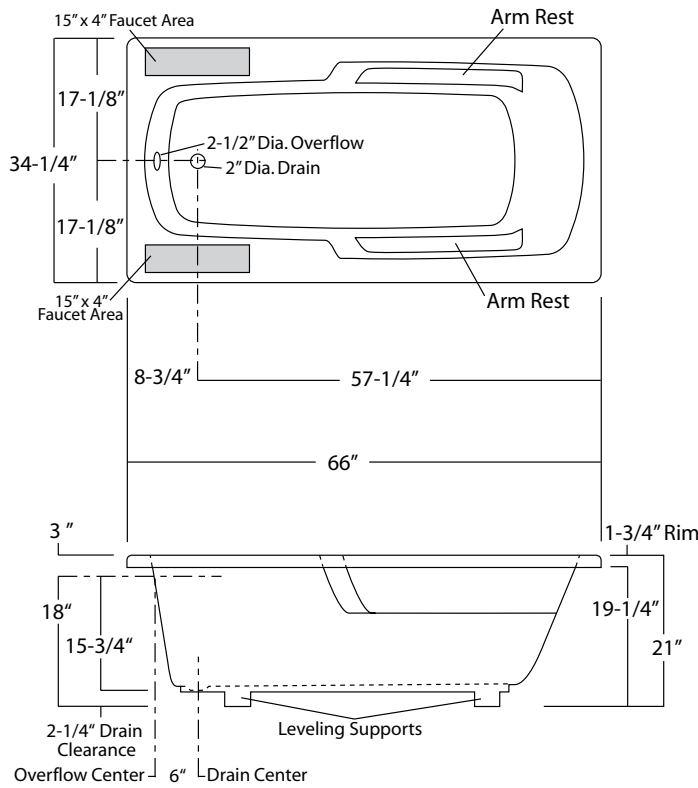

Revive Air System

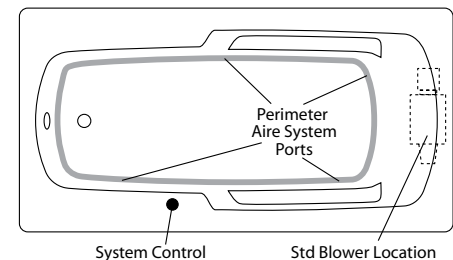

Prestige 3466: TR-B-220
 Sump Dimen: 53" long x 20-1/2" wide x 17-3/4" deep

Photographic images may include optional components and appear different than actual product. Dimensions shown are maximum. Due to the nature of the materials involved, actual unit dimensions can vary (tolerances: +0 / -3/8 inch). Oasis reserves the right to modify or discontinue product and/or associated equipment without prior written or verbal notification or obligation.